

INSTRUCTION MANUAL

AIR / WATER RETRACTABLE HOSE REELS

Model L-AWP1030 - L-AWP1220



AIR / WATER RETRACTABLE HOSE REEL

DESCRIPTION

Thank you for purchasing a Lubemate hose reel. Each reel is a quality UV Stabilised reel, supplied complete with a delivery hose, feeder hose and mounting bracket.

FEATURES AND BENIFITS

1. The hose reel is UV stabilised.
2. The reel is easy to use positive latch and a built in hose layering mechanism to prevent hose bunching.
3. Durable construction, made from high quality impact resistant polypropylene, light in weight and more compact.
4. A powerful spring winds the hose back into the drum.

CAUTION

GENERAL SAFETY

Please read these operating instructions carefully and note the information given. Use these operating instructions to familiarize yourself with the product, the proper use and the safety instructions.



- * To prevent injury or damage do not let go of the hose during rewinding.
- * Hold the hose stop ball when retracting hose.
- * **Do not** disassemble hose reel.
- * Ensure the reel or hose is not in contact with any sharp objects or exposed to high temperatures.
- * **Do not** drop this reel or damage will occur.
- * **Do Not** use this product with any chemicals or liquid other than air/water.
- * Turn off air supply after use or at the end of the day.

Installation:

1. Take out the unit and accessories from the box,
2. Choose a suitable place near source of air/water.
3. Take the mounting bracket as a template to mark the position for screws and drill four holes on the wall (Fig.2)

1	Hose reel	1
2	Mounting bracket	1
3	Self-tapping bolts	4

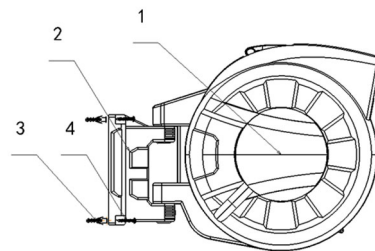

4. Fix the bracket by four self-taping screws accordingly, (Fig.1)

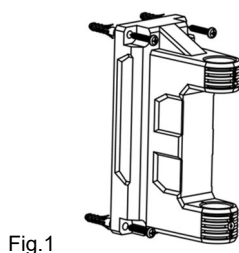

Fig.1

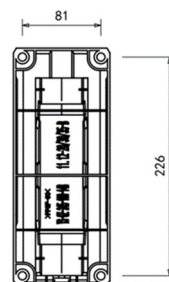

Fig.2

AIR / WATER RETRACTABLE HOSE REEL

5. Connect the reel to the mounting bracket.

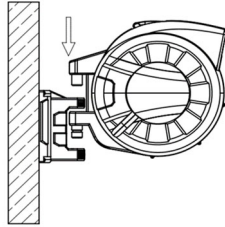

Fig.3

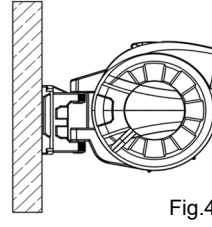

Fig.4

Note:

1. The reel should be installed horizontally to a wall or post.
2. It is recommended to mount the reel approximately 1 meter above the ground.

Operation

1. Connect feeder hose and turn on supply
2. Pull out hose to desired length and stop.

Retract hose

1. Always hold hose when retracting back into reel
2. Turn off the air/water supply.

Storage

Cleaning

This Reel is maintenance-free and must not be cleaned internally with water.

Maintenance

When not in use, turn off supply, and release the line pressure

The reel must not be used to transmit any chemical and substance

When not in use for an extended period of time it is recommended to be stored in a cool dry place.

Item	Description	Material	No off
22	Lock System	PA	1
21	Mounting Bracket	PP+GF30	1
20	Handle	PP	1
19	Block Piece	POM	1
18	Aluminium Shaft	Aluminium	1
17	O-Ring	NBR	1
16	Inlet	Brass	1
15	Right Cover	PP	1
14	Right Casing	PP	1
13	Synchronous belt	PU	1
12	Spring Shaft	45#	1
11	Spring Cover	PP+GF30	1
10	Spring	62SI2MN	1
9	Slow return mechanism	PP+POM	1
8	Drum	PP+GF30	1
7	Hose guide system	PA+POM	1
6	Output hose	Hybrid	1
5	Hose Stop	PP	1
4	Lead hose	Hybrid	1
3	Tooth Wheel	POM	1
2	Left Casing	PP	1
1	Left Cover	PP	1

EXPLODED DIAGRAM

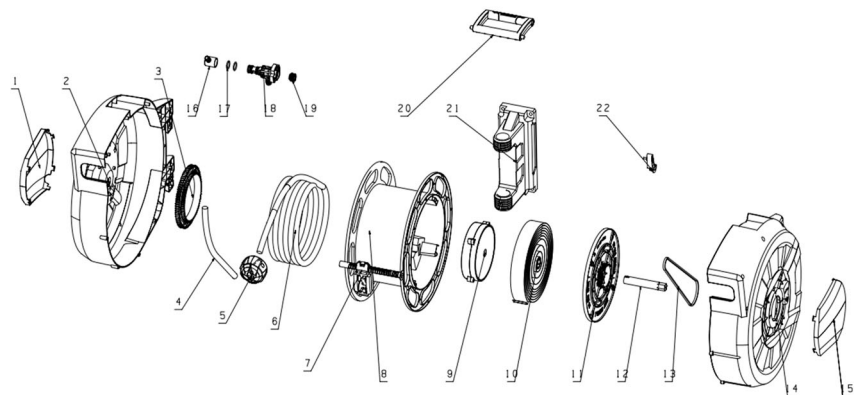

Note: no spare parts available

AIR / WATER RETRACTABLE HOSE REEL

TROUBLESHOOTING

FAULT	DESCRIPTION	SOLUTION
The hose does not retract	Hose has been pulled out too far and locked	Access the drum through the window and carefully rotate the drum half a turn in the direction of the hose being pulled out to release latch.
	Not enough spring tension	Add 1-2 turns extra turns: 1. Remove the small cover, 2. Use spanner to clamp the groove of preload wheel, 3. Unscrew four bolts on the wheel, then rotate it for 1-2 turns in counterclockwise, then fasten the bolts, and replace the cover. Fig.4

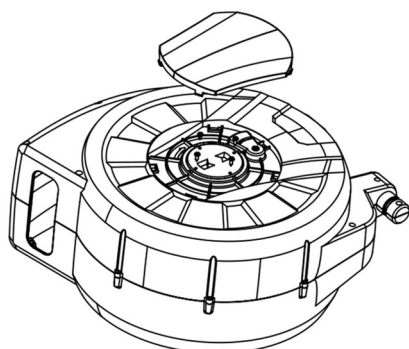

Fig.5

SPECIFICATIONS	L-AWP1030	L-AWP1220
Maximum Pressure	300psi/20bar	300psi/20bar
Maximum Temperature	+ 55 deg C	+ 60 deg C
Hose type	Hybrid Polymer	Hybrid Polymer
Hose Size and Length	3/8" (10mm) x 30m	1/2" (12.5mm) x 20m
Inlet / Outlet	1/4" BSPT (M)	3/8" BSP (M)
Dimensions	51 x 24.5 x 46.8cm	51 x 24.5 x 46.8cm
Weight	11kgs	11kgs

For warranty terms and conditions refer to
www.macnaught.com.au